

# Z-VENT COAXIAL HORIZONTAL TERMINATION

## KIT: 2SVSHTCKIT SUPPLEMENTAL INSTRUCTIONS

### CONTENTS INCLUDES

(1/each in appropriate diameter except where noted):

COAXIAL TERMINATION	Vent /Air Intake Diameter (IN)	Back of Wall Plate to Centerline Vent/Air Intake Min-Max (IN)	Maximum Wall Thickness (IN)
2SVSHTC03S	3/3	8-12	9
2SVSHTC03	3/3	12-21	17.5
2SVSHTC43S	4/3	8-12	9
2SVSHTC43	4/3	12-21	17.5
2SVSHTC04S	4/4	8-12	9
2SVSHTC04	4/4	12-21	17.5
2SVSHTC05S	5/5	11-17	12
2SVSHTC05	5/5	17-21	17.5

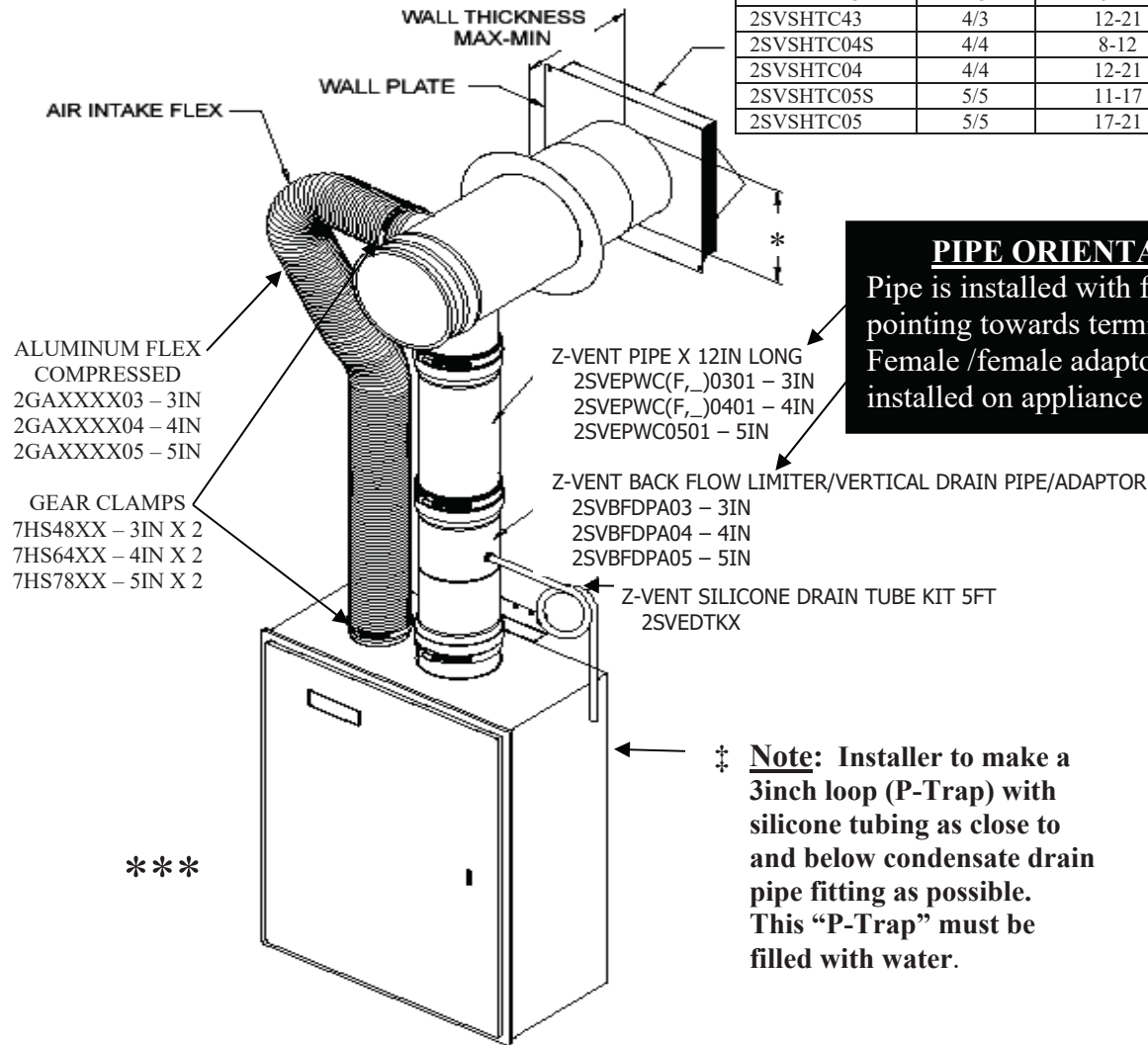

### PIPE ORIENTATION

Pipe is installed with female end pointing towards termination. Female /female adaptor MUST be installed on appliance flue outlet.

### Illustration 1

\*\*\* Refer to the appliance manufacture installation manual for recommended vent configuration.

‡ Refer to Z-Vent® Installation Guide for proper installation of Z-Vent® components  
Click on the “Downloads” on our [www.z-flex.com](http://www.z-flex.com) website under Z-Vent® Section

FLEXMASTER CANADA LTD  
452 ATTWELL DR.  
M9W 5C3  
ETOBICOKE, ONTARIO  
(416) 679-0045

Z-FLEX US, INC.  
20 COMMERCE PARK, NORTH  
BEDFORD, N.H.  
03110-691  
1(800) 654-5600

Visit our web site at [www.z-flex.com](http://www.z-flex.com)

## Z-VENT® CLEARANCE TO COMBUSTIBLES

SYSTEM OPERATING TEMPERATURE	CLEARANCE ENCLOSED		CLEARANCE UNENCLOSED	
	HORIZONTAL	VERTICAL	HORIZONTAL	VERTICAL
300°F (149°C)	8" (200 mm)	4"(100 mm)	1"(25 mm)	1" (25 mm)
480°F (249°C)	8"(200 mm)	4"(100 mm)	1" (25 mm)	1" (25 mm)

### SIDE WALL VENTING INSTALLATION

1. Refer to the appliance manufacturer for recommended termination location following all applicable codes and regulations having jurisdiction. Select the point of wall penetration where the minimum pitch of ¼" per foot of slope (6.4 mm per 305 mm) back to condensate drain can be maintained. A framed opening is required to insert the concentric halves. The Concentric Termination is adjustable for different wall thicknesses. Caulk around outside edge of plates as necessary and fasten to wall using suitable screws or nails.

#### \*Termination Hole Sizes

**2SVSHTC03** requires standard **5 inch** drill size      **2SVSHTC43** requires standard **6 inch** drill size

**2SVSHTC04** requires standard **7 inch** drill size      **2SVSHTC05** requires standard **8 inch** drill size

#### **NOTE:**

\*The coaxial terminations "outer wall" is CSA tested for "0 inch" clearance to combustibles for **Takagi water heaters**.

2. The system can now be assembled from the appliance to the Concentric Termination as in illustration 1 above and using the **JOINT PROCEDURE** as described in the accompanying Z-Vent® Installation Guide.

#### **NOTICE**

Z-Flex® recommends that a condensate drain of suitable configuration be installed in the venting system so that any condensate produced in the vent system is allowed to drain before collecting in the appliance.

#### **CAUTION**

When installing the condensate tube be sure to form a trap by means of a 3 inch (76.2 mm) loop filled with water as close to and below the connection to condensate drain fitting. This tube must be 3/8 inch ID high temperature silicone for at least the first 6 inches (152 mm) and attached with a gear clamp or hose clamp. The effluent must be disposed of according to local regulations.

#### **NOTICE**

Z-Flex® recommends using a neutralizer kit when using a condensate trap. A condensate pump may be required. Contact the heating appliance manufacturer to determine if this recommendation is applicable.

#### **DANGER**

**DO NOT DRILL HOLES** for "test-ports", or to use fasteners such as screws, rivets, etc. into any part of the entire vent system to connect pipes or fittings or when using support straps.

#### **HOW TO CUT PIPE**

When measuring the length of pipe make certain to account for the 2inch insertion depth prior to cutting. The lengths of pipe may be cut on the non-expanded end using a hacksaw (24 tpi blade) or aviation snips. Make certain to cut the end straight and keep the end cylindrical. The cut end edge must be filed or sanded smooth before joining (see images 6 & 7).

- i) Measure 2 inches from cut end and draw a line to indicate depth insertion.
- ii) Insert male end into female end to within ¼ inch of the drawn line to achieve full depth insertion.

#### **DANGER**

**Cut pipe joint connections not meeting the full insertion criteria will cause severe personal injury, death or substantial property damage.**

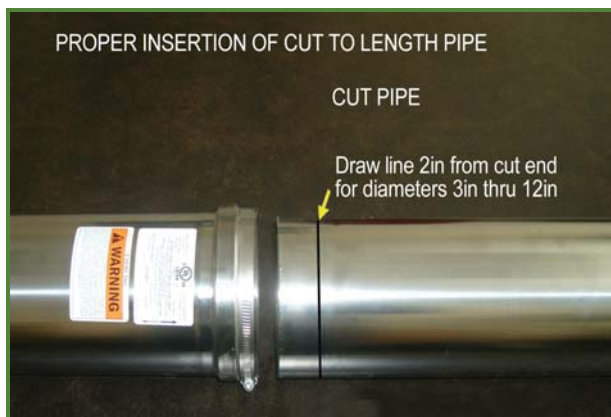

IMAGES 6 & 7